

# Wafer Grippers SWGm

Two suction areas suitable for wafer sizes 115 x 115 mm and 146 x 146 mm

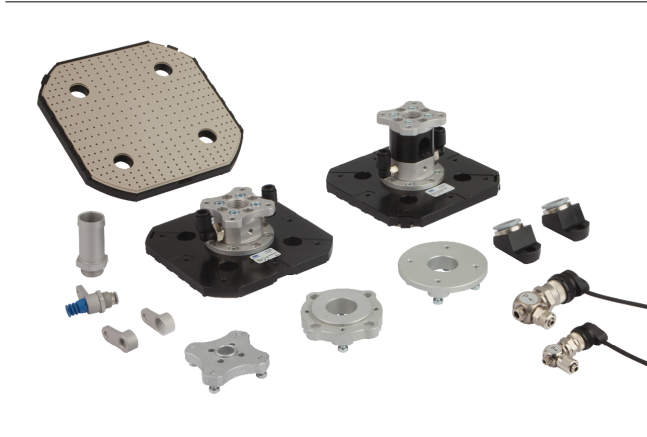

Wafer Grippers SWGm

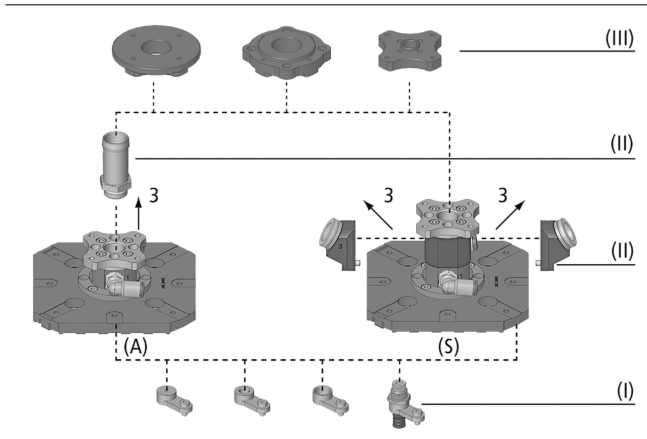

System design Wafer Grippers SWGm

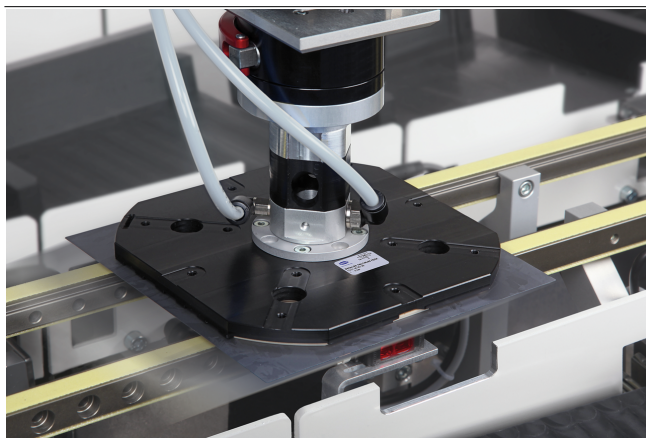

Wafer grippers SWGm being used for handling solar cells

## Suitability for industry specific applications

### Application

- Wafer gripper for extremely fast and gentle handling of wafers and solar cells in the production processes
- Loading and unloading from stacks and conveyor belts
- Exact positioning during the visual inspection and position measurement allow for on-the-fly breakage detection during the handling process
- Fully or partially automated production of PV cells with maximum process stability, production line uptime, cell efficiency and line output

### Design

- Base model version with discharging exhaust air (3) in axial (A) or lateral (S) direction
- Suction area geometries available in common cell sizes 125 mm and 156 mm (5" and 6")
- Optional component (II) for controlled discharging of exhaust air
- Modular design with accessories for the mounting of sensors and modules for suction and damping (I) and a selection of flange modules (III)
- Minimal overall height through reduced-weight plastic design
- Replaceable contact surfaces

### Product highlights

- Fast and accurate positioning, with cycle times of less than one second thanks to low height and weight
- Optimal distribution and dimensioning of suction points reduces breakage rate
- High suction capacity allows safe gripping even with partial occupancy or leakage e.g. with perforated wafers

# Wafer Grippers SWGm

Two suction areas suitable for wafer sizes 115 x 115 mm and 146 x 146 mm

## Designation code Wafer Grippers SWGm

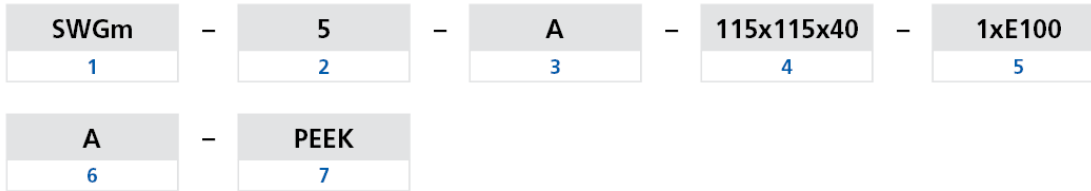

### 1 – Abbreviated designation

Code	Version
SWGm	SWGm

### 2 – Size

Code	Size in inch
5...6	5 to 6

### 3 – Design

Code	Type
A	Axial exhaust air
S	Lateral exhaust air

### 4 – Dimensions

Code	Dimensions in mm
115x115x40...	115x115x40 and
146x146x65	146x146x65

### 5 – Performance class of ejector

Code	Performance class of ejector
1xE100	1xE100

### 6 – Blow off function

Code	Type
A	Blow off function

### 7 – Material suction area

Code	Material suction area
PEEK	Polyetheretherketon

Wafer gripper SWGm is delivered assembled. The assembly consists of:

- Wafer gripper of type SWGm – available in various dimensions, with axial or lateral exhaust

Available spare parts: suction area

Available accessories: component for discharging exhaust air, holder system, suction/absorption module, floating suction cup module, exhaust duct, solenoid valves, flange plate

## Ordering data Wafer Grippers SWGm

Type	Part no.
SWGm-5A 115x115x40 1xE100 A PEEK	10.01.30.00135
SWGm-6A 146x146x40 1xE100 A PEEK	10.01.30.00136
SWGm-5S 115x115x65 1xE100 A PEEK	10.01.30.00137
SWGm-6S 146x146x65 1xE100 A PEEK	10.01.30.00138

## Ordering data Spare parts Wafer Grippers SWGm

Type	Spare parts	Part no.
SWGm-5A 115x115x40 1xE100 A PEEK	Suction area SAUG-FL SWGm-5 110x110 PEEK	10.01.30.00125
SWGm-6A 146x146x40 1xE100 A PEEK	Suction area SAUG-FL SWGm-6 141x141 PEEK	10.01.30.00126
SWGm-5S 115x115x65 1xE100 A PEEK	Suction area SAUG-FL SWGm-5 110x110 PEEK	10.01.30.00125
SWGm-6S 146x146x65 1xE100 A PEEK	Suction area SAUG-FL SWGm-6 141x141 PEEK	10.01.30.00126

# Wafer Grippers SWGm

Two suction areas suitable for wafer sizes 115 x 115 mm and 146 x 146 mm

## Ordering data Accessories Wafer Grippers SWGm

Type	Flange plate AD1	Flange plate UNI	Flange plate ST1	Flange plate JP1	Flange plate EL1	Flange plate AB1	Holder system HTR-UNI	Holder system HTR-M8
SWGm-5A 115x115x40 1xE100 A PEEK	10.01.30.00016	10.01.30.00017	10.01.30.00167	10.01.30.00194	-	-	10.01.30.00117	10.01.30.00118
SWGm-6A 146x146x40 1xE100 A PEEK	10.01.30.00016	10.01.30.00017	10.01.30.00167	10.01.30.00194	-	-	10.01.30.00117	10.01.30.00118
SWGm-5S 115x115x65 1xE100 A PEEK	10.01.30.00016	10.01.30.00017	10.01.30.00167	10.01.30.00194	10.01.30.00208	10.01.30.00015	10.01.30.00117	10.01.30.00118
SWGm-6S 146x146x65 1xE100 A PEEK	10.01.30.00016	10.01.30.00017	10.01.30.00167	10.01.30.00194	10.01.30.00208	10.01.30.00015	10.01.30.00117	10.01.30.00118

Type	Holder system HTR M12	Suction-/ absorption module	Floating suction cup module	Solenoid valve EMV 1.5	Solenoid valve EMV 2.5	Exhaust duct	Exhaust air set
SWGm-5A 115x115x40 1xE100 A PEEK	10.01.30.00119	10.01.30.00121	10.01.01.12912	10.05.01.00288	10.05.01.00289	10.01.30.00087	-
SWGm-6A 146x146x40 1xE100 A PEEK	10.01.30.00119	10.01.30.00121	10.01.01.12912	10.05.01.00288	10.05.01.00289	10.01.30.00087	-
SWGm-5S 115x115x65 1xE100 A PEEK	10.01.30.00119	10.01.30.00121	10.01.01.12912	10.05.01.00288	10.05.01.00289	-	10.01.30.00059
SWGm-6S 146x146x65 1xE100 A PEEK	10.01.30.00119	10.01.30.00121	10.01.01.12912	10.05.01.00288	10.05.01.00289	-	10.01.30.00059

## Technical data Wafer Grippers SWGm

Type	Holding force [N]	Suction rate [l/min]	Air consumption [l/min]	Pressure range (operating pressure) [bar]	Operating temperature [°C]	Weight [g]
SWGm-5A 115x115x40 1xE100 A PEEK	10 ... 35 N	190 ... 350 l/min	60 ... 120 l/min	1.0 ... 3.0 bar	5 ... 75 °C	210
SWGm-6A 146x146x40 1xE100 A PEEK	12 ... 43 N	190 ... 350 l/min	60 ... 120 l/min	1.0 ... 3.0 bar	5 ... 75 °C	275
SWGm-5S 115x115x65 1xE100 A PEEK	10 ... 35 N	160 ... 235 l/min	60 ... 120 l/min	1.0 ... 3.0 bar	5 ... 75 °C	235
SWGm-6S 146x146x65 1xE100 A PEEK	12 ... 43 N	160 ... 235 l/min	60 ... 120 l/min	1.0 ... 3.0 bar	5 ... 75 °C	300

# Wafer Grippers SWGm

Two suction areas suitable for wafer sizes 115 x 115 mm and 146 x 146 mm

## Performance data Wafer Grippers SWGm

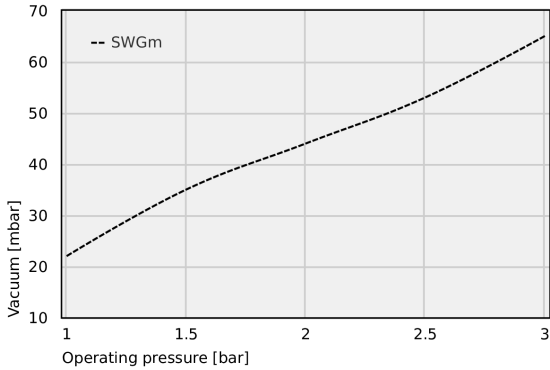

Achievable vacuum at various operating pressures

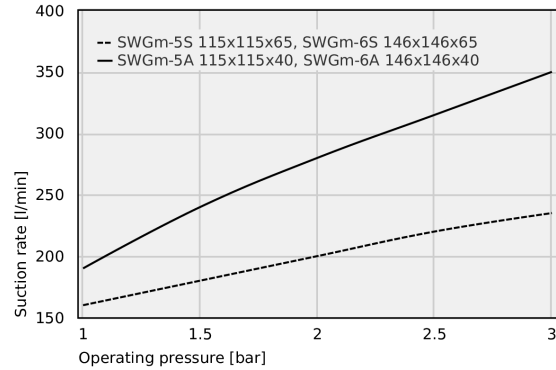

Suction rate at various degrees of evacuation

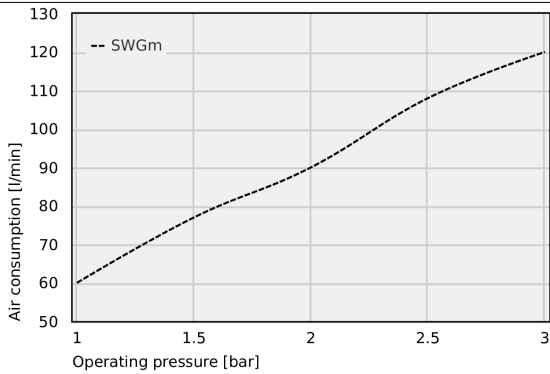

Air consumption

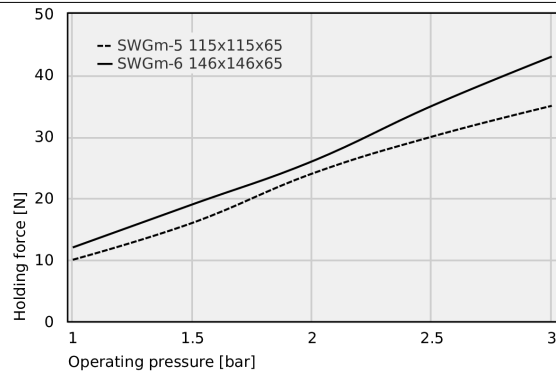

Holding force

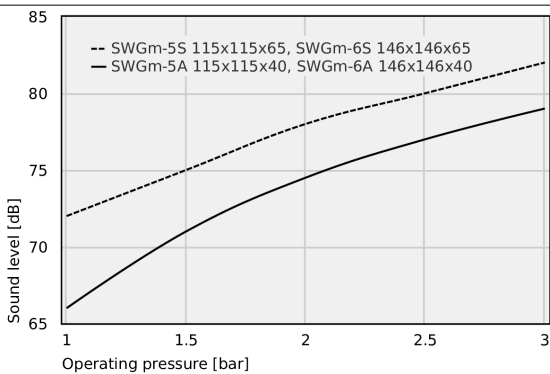

Sound level "free suction" at various operating pressures

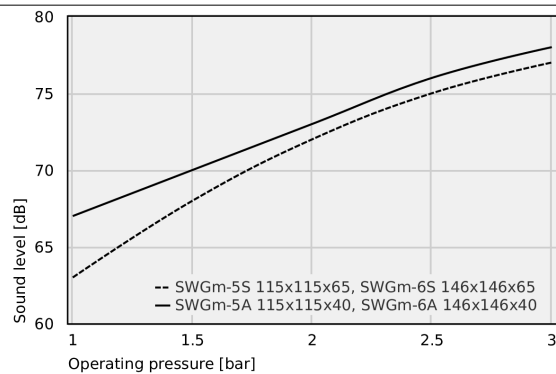

Sound level workpiece gripped at various operating pressures

## Achievable vacuum at various operating pressures

Typ	1	1.5	2	2.5	3
SWGm	22.00	35.00	44.00	53.00	65.00

## Wafer Grippers SWGm

Two suction areas suitable for wafer sizes 115 x 115 mm and 146 x 146 mm

### Suction rate at various degrees of evacuation

Typ	1	1.5	2	2.5	3
SWGm-5S 115x115x65, SWGm-6S 146x146x65	160.00	180.00	200.00	220.00	235.00
SWGm-5A 115x115x40, SWGm-6A 146x146x40	190.00	240.00	280.00	315.00	350.00

### Air consumption

Typ	1	1.5	2	2.5	3
SWGm	60.00	77.00	90.00	108.00	120.00

### Holding force

Typ	1	1.5	2	2.5	3
SWGm-5 115x115x65	10.00	16.00	24.00	30.00	35.00
SWGm-6 146x146x65	12.00	19.00	26.00	35.00	43.00

### Sound level "free suction" at various operating pressures

Typ	1	1.5	2	2.5	3
SWGm-5S 115x115x65, SWGm-6S 146x146x65	72.00	75.00	78.00	80.00	82.00
SWGm-5A 115x115x40, SWGm-6A 146x146x40	66.00	71.00	74.50	77.00	79.00

### Sound level workpiece gripped at various operating pressures

Typ	1	1.5	2	2.5	3
SWGm-5S 115x115x65, SWGm-6S 146x146x65	63.00	68.00	72.00	75.00	77.00
SWGm-5A 115x115x40, SWGm-6A 146x146x40	67.00	70.00	73.00	76.00	78.00

# Wafer Grippers SWGm

Two suction areas suitable for wafer sizes 115 x 115 mm and 146 x 146 mm

## Design data Wafer Grippers SWGm

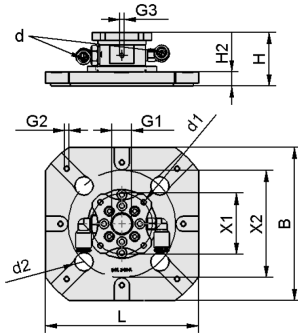

SWGm-5A, SWGm-6A

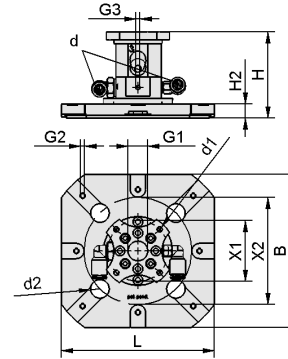

SWGm-5S, SWGm-6S

## Wafer Grippers SWGm

Two suction areas suitable for wafer sizes 115 x 115 mm and 146 x 146 mm

### Design data Wafer Grippers SWGm

Type	B [mm]	d [mm]	d1 [mm]	d2 [mm]	G1	G2		H [mm]	H2 [mm]	L [mm]	X1 [mm]	X2 [mm]
SWGm-5A 115x115x40 1xE100 A PEEK	115	6	4	14	G3/8"-F	M4-F	M4-F	40	10.5	115	46	80.6
SWGm-6A 146x146x40 1xE100 A PEEK	146	6	4	14	G3/8"-F	M4-F	M4-F	40	10.5	146	46	110.6
SWGm-5S 115x115x65 1xE100 A PEEK	115	6	4	14	G3/8"-F	M4-F	M4-F	65	10.5	115	46	80.6
SWGm-6S 146x146x65 1xE100 A PEEK	146	6	4	14	G3/8"-F	M4-F	M4-F	65	10.5	146	46	110.6